

## P4200DA SOD-123FL

### Description

Thyristors are a type of semiconduct component. They are designed to protect baseband equipment from damaging overvoltage transients. such as modems, telephones, line cards, answering machines, FAX machines, T1/E1, xDSL and more.

### Features

- Excellent capability of absorbing transient surge
- Quick response to surge voltage (ns Level)
- Eliminates overvoltage caused by fast rising transients
- Moisture sensitivity level: Level 1
- Fails short circuit when surged in excess of ratings
- Non degenerative

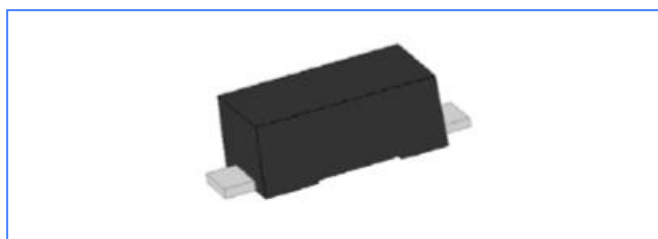

### Device Symbol

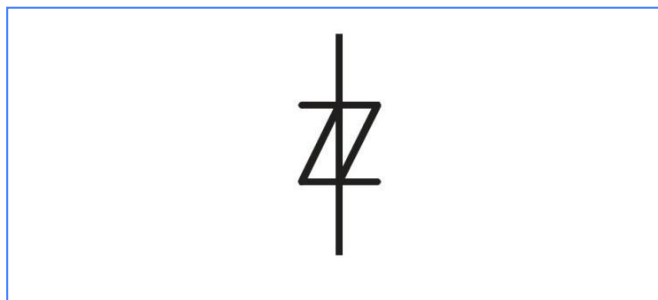

### Typical Applications

Parameter	Definition
$V_{DRM}$	Peak Off-state Voltage – maximum voltage that can be applied while maintaining off state
$V_S$	Switching Voltage – maximum voltage prior to switching to on state
$V_T$	On-state Voltage – maximum voltage measured at rated on-state current
$I_{DRM}$	Leakage Current – maximum peak off-state current measured at $V_{DRM}$
$I_S$	Switching Current – maximum current required to switch to on state
$I_T$	On-state Current – maximum rated continuous on-state current
$I_H$	Holding Current – minimum current required to maintain on state
$C_O$	Off-state Capacitance – typical capacitance measured in off state
$I_{PP}$	Peak Pulse Current – maximum rated peak impulse current

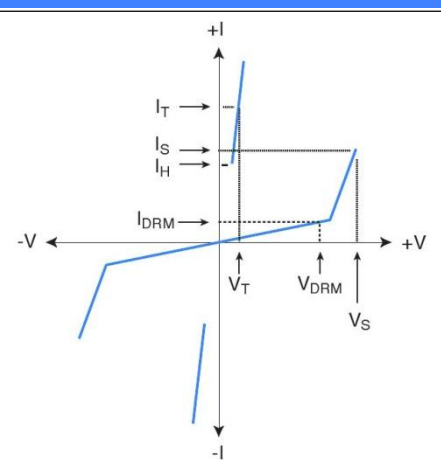

### Thermal Consideration

Parameter	Symbol	Value	Unit
Operating Temperature	$T_J$	-40 to +125	°C
Storage Temperature	$T_{STG}$	-40 to +125	°C

### Summary Electrical Characteristics, $T_a = 25^\circ C$ (Unless Otherwise Noted)

Parameter Description	$I_{DRM}@V_{DRM}$		$V_S^{①}@I_S$		$V_T@I_T$		$I_H$	$C_O^{②}$
	$\mu A$	V	V	mA	V	A		
Unit	$\mu A$	V	V	mA	V	A	mA	pF
Type	max	min	max	max	max	max	typ	max
P4200DA	5	400	520	800	4.0	2.2	10	50

- ①Vs is measured at 100KV/s
- ②Off-state capacitance is measured in VDC=2V, VRMS=1V, f=1MHz

### Surge Ratings

Type	Wave Sharp		VPP
IEC6100-4-5	Voltage	10/700μs	2000V

### Rating & Characteristic Curves

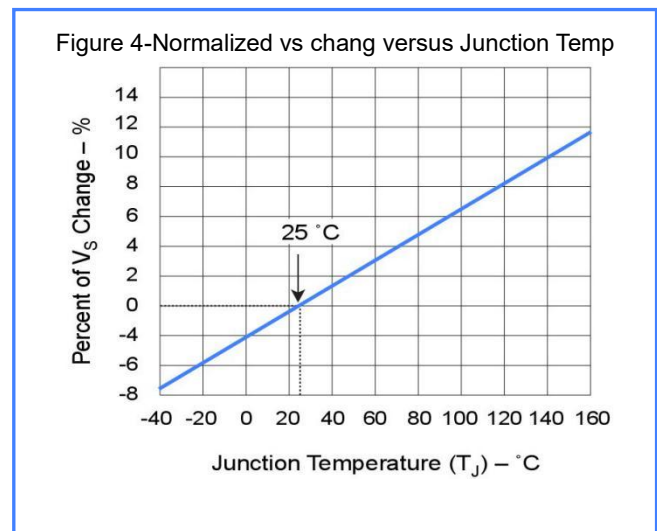
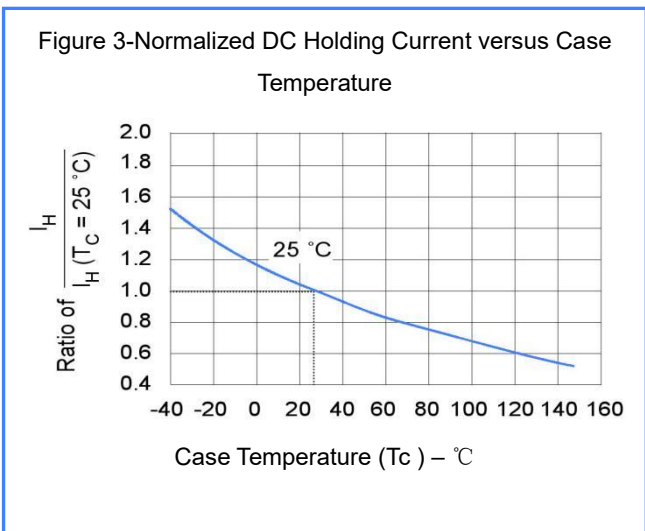
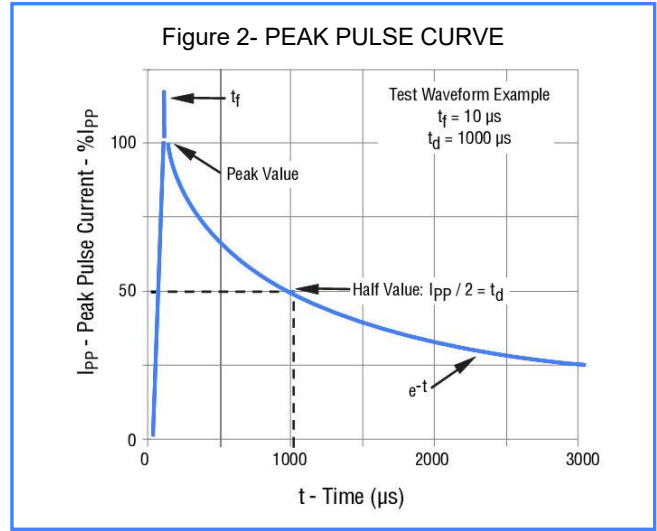
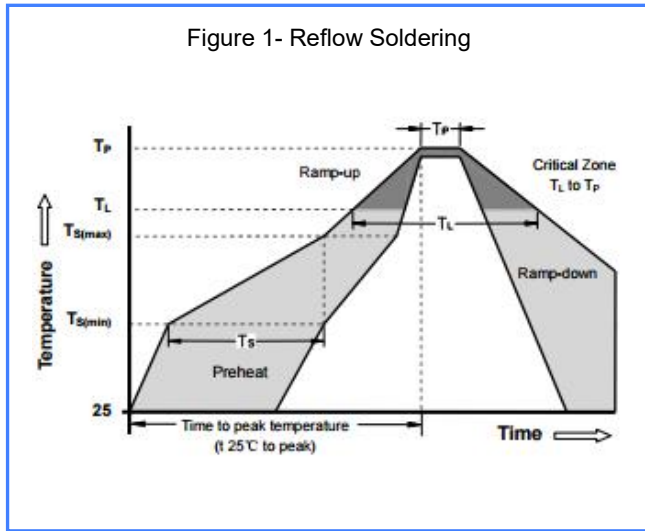

**PACKAGE OUTLINE DIMENSIONS in millimeters**

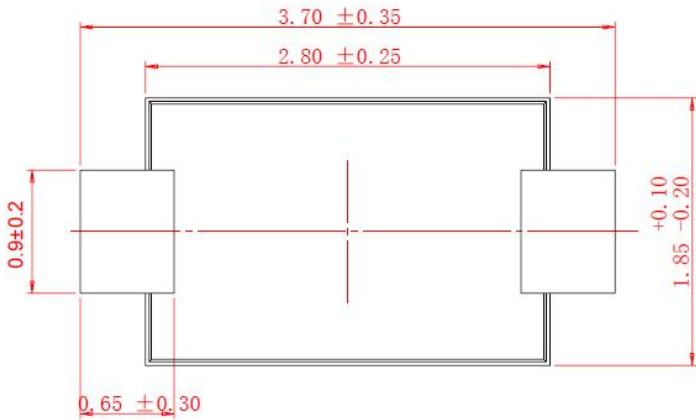
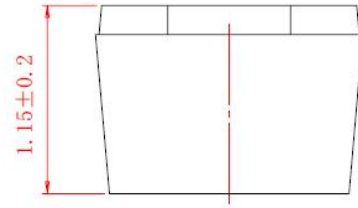
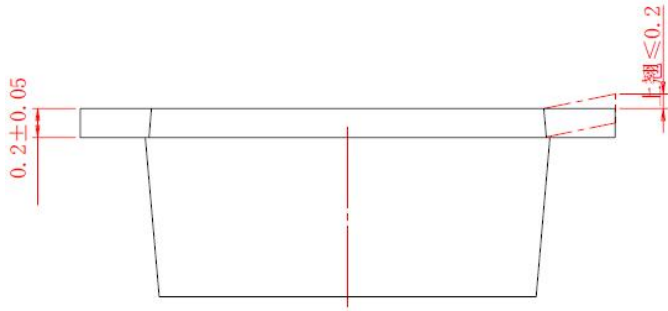

**Mounting Pad Layout**

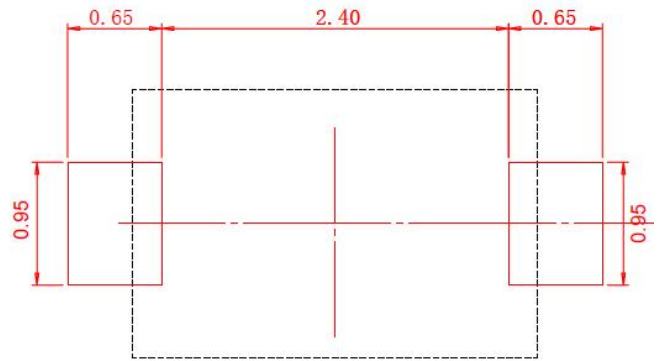

**Disclaimer**

Specifications are subject to change without notice.

The device characteristics and parameters in this data sheet can and do vary in different applications and actual device performance may vary over time.

Users should verify actual device performance in their specific applications.